

## General Specifications

**Motor Structure:** Shaded Pole Induction Motor  
**Motor Protection:** Impedance Protection  
**Insulation Resistance:**  
 10M Ω or over with a DC500V Megger  
**Dielectric Withstand Voltage:** AC 700V 1s  
**Allowable Ambient Temperature Range:**  
 -10°C ~ +70°C (Operating)  
 -40°C ~ +70°C (Storage)  
 (non-condensing environment)

## Expected Life

**Failure Rate: 10%**  
 25°C 50,000 Hours

## Material

**Casing :** Aluminum  
**Impeller :** Polycarbonate (Glass Fiber-Containing)  
**Bearing :** Ball Bearing  
**Lead Wire :** AWG22, UL3266, CSA CLR52  
**or Terminal :** Faston #110 or equivalent

## Panel Cut-Outs

Units:  $\frac{\text{inch}}{\text{mm}}$

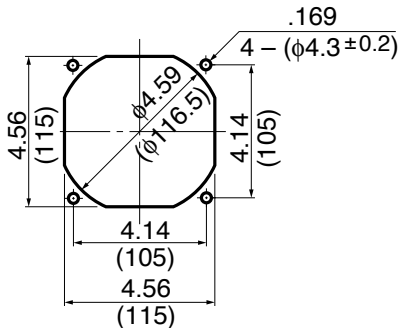

INLET SIDE / OUTLET SIDE

## Outline

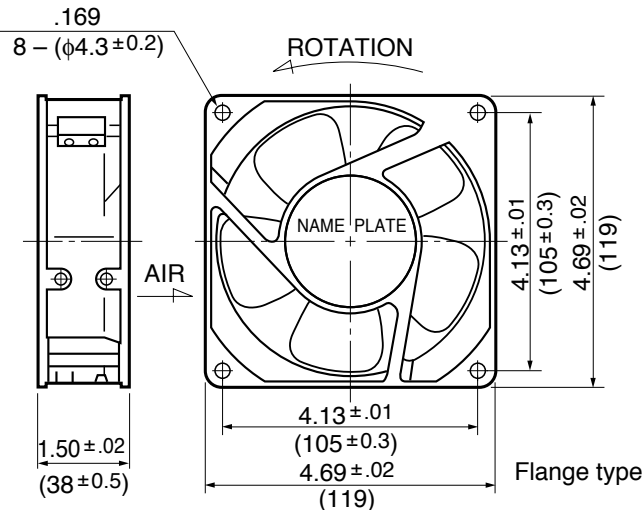

## Characteristic Curves

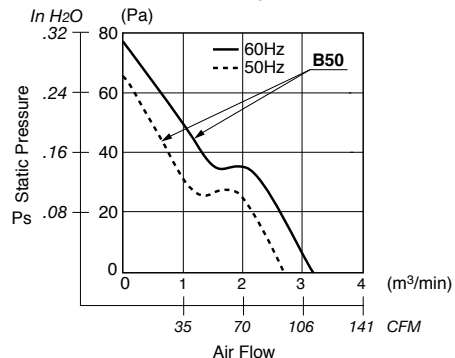
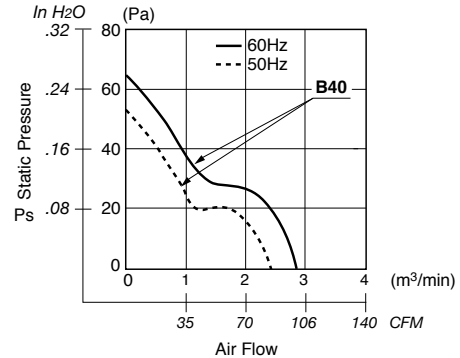
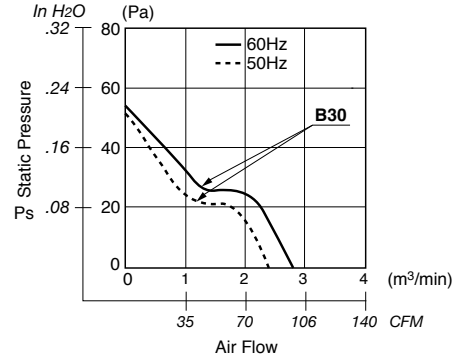
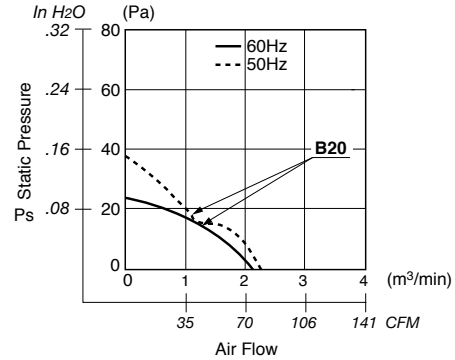
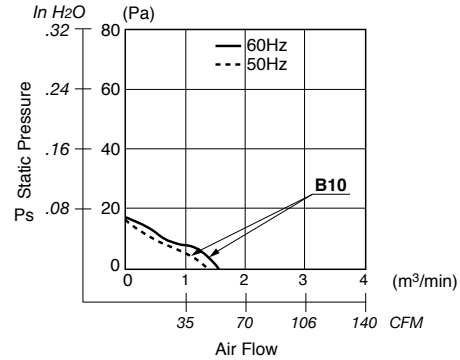

## Specifications

MODEL	Rated Voltage	Frequency	Starting Voltage	Current	Input Power	Speed	Max. Air Flow		Max. Static Pressure		Noise	Mass
	(V)	(Hz)	(V)	(A) <sup>*1</sup>	(W) <sup>+10% -20%</sup>	(min <sup>-1</sup> ) <sup>*3</sup>	CFM	(m <sup>3</sup> /min) <sup>*3</sup>	in H <sub>2</sub> O	(Pa) <sup>*3</sup>	(dB) <sup>*2</sup>	(g)
4715MS-12T-B50-A00	115	50	65	0.250	15.5	2600	88.2	2.50	.259	64.6	37.0	550
	115	60	65	0.210	14.5	2900	102.0	2.90	.309	76.4	41.0	550
4715MS-23T-B50-A00	230	50	175	0.120	15.0	2600	88.2	2.50	.255	63.7	37.0	550
	230	60	175	0.100	14.0	2900	102.0	2.90	.283	70.5	41.0	550
4715MS-12T-B40-A00	115	50	75	0.220	15.0	2450	85.0	2.40	.204	50.9	35.0	550
	115	60	75	0.190	13.0	2750	95.0	2.70	.259	64.6	39.0	550
4715MS-23T-B40-A00	230	50	175	0.120	15.0	2450	85.0	2.40	.216	53.9	35.0	550
	230	60	175	0.100	13.0	2750	95.0	2.70	.255	63.7	39.0	550
4715MS-12T-B30-A00	115	50	75	0.160	11.0	2400	81.0	2.30	.200	49.9	34.0	550
	115	60	75	0.140	10.0	2600	88.2	2.50	.200	49.9	37.0	550
4715MS-23T-B30-A00	230	50	175	0.100	12.0	2400	81.0	2.30	.197	49.0	34.0	550
	230	60	175	0.080	11.0	2600	88.2	2.50	.208	51.9	37.0	550
4715MS-12T-B20-A00	115	50	75	0.100	7.0	2100	76.6	2.00	.141	35.2	32.0	550
	115	60	75	0.100	7.0	1950	67.0	1.90	.098	24.5	30.0	550
4715MS-23T-B20-A00	230	50	175	0.060	7.5	2100	70.6	2.00	.141	35.2	32.0	550
	230	60	175	0.060	7.5	1900	67.0	1.90	.086	21.5	30.0	550
4715MS-12T-B10-A00	115	50	75	0.090	6.0	1350	45.9	1.30	.062	15.6	27.0	550
	115	60	75	0.080	5.5	1450	49.4	1.40	.066	16.6	28.0	550
4715MS-23T-B10-A00	230	50	175	0.050	6.5	1350	45.9	1.30	.059	14.7	27.0	550
	230	60	175	0.045	6.0	1450	49.4	1.40	.059	14.7	28.0	550

Rotation: Counterclockwise

Airflow Outlet: Air Out Over Struts

\*1: Maximum Values in Free Air

\*2: Average Values in Free Air

\*3: Minimum Values in Free Air